

THIS COPY IS PROVIDED ON A RESTRICTED BASIS AND IS NOT TO BE USED IN ANY WAY DETRIMENTAL TO THE INTERESTS OF PANDUIT CORP.

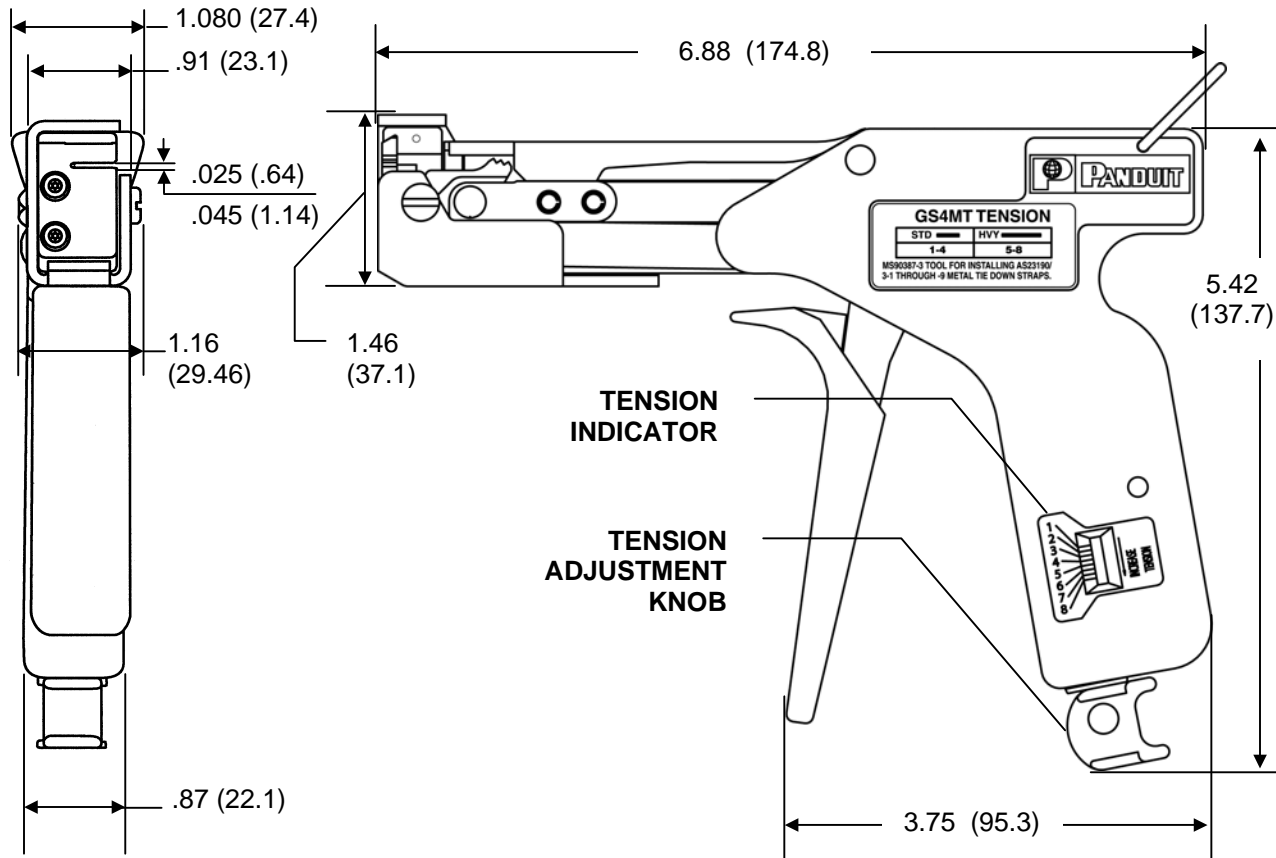

**SPECIFICATIONS:**

PANDUIT TOOL NO.: GS4MT  
 TOOL WEIGHT: 19.2 oz. (544 gr.)

INSTALLS PANDUIT PAN-STEEL STANDARD (STD), LIGHT-HEAVY (LH) AND HEAVY (HVY) CROSS SECTION STAINLESS STEEL TIES.

- THIS MILITARY STANDARD MS-90387-3 TOOL CAN BE USED TO INSTALL THE FOLLOWING MLT STRAPS: AS23190/3-1,2,3,4,5,6,7,8,9
- THIS TOOL TIGHTENS STAINLESS STEEL TIES AND CUTS OFF EXCESS PORTION WHEN PRESET TENSION IS ATTAINED
- SUPPLIED WITH SELECTOR KNOB FOR TENSION ADJUSTMENT.

DIMENSIONS SHOWN IN PARENTHESES ARE METRIC

**PANDUIT** CORP. TINLEY PARK, ILLINOIS

**GS4MT CUSTOMER DRAWING**

UNLESS OTHERWISE SPECIFIED, DIMENSIONAL TOLERANCES ARE:

(.x) ± --- (.xxx) ± ---  
 (.xx) ± --- ANGLES ± ---

UNLESS OTHERWISE SPECIFIED, ALL DIMENSIONS ARE GIVEN IN INCHES, THIRD ANGLE PROJECTION.

02	10-25-06	BLR	ABJ	UPDATE STRAP SPEC "MLT / AS"	4198	--	LAH	
01	7-25-05	BLR	ABJ	REDRAWN WITH CHANGES: STRAP RANGE, WEIGHT (OZ).	4156	--	DLWE	
REV	DATE	BY	CHK'D	DESCRIPTION	ECN	-R	CUST	SUP

DRAWN BY:  
**BLR**

DATE:  
**7-25-05**

CHK'D:  
**BAK**

MATL:  
**CUSTOMER DRAWING**

SCALE  
**NONE**

DRAWING NO.  
**WB17905A01**

DWG  
**A**  
SIZE