

# SPECIFICATION CONTROL DRAWING

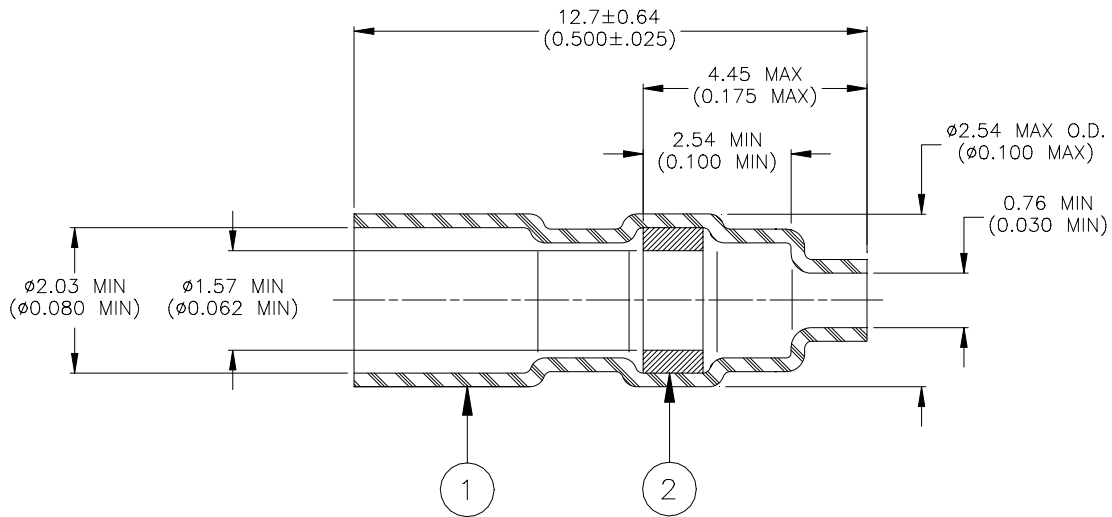

## MATERIALS

1. INSULATION SLEEVE: Heat shrinkable, transparent blue, radiation cross-linked polyvinylidene fluoride.
2. SOLDER PREFORM WITH FLUX:  
 SOLDER: TYPE Sn63 per ANSI J-STD-006.  
 FLUX: TYPE ROL1 per ANSI J-STD-004.

## APPLICATION

1. This part is designed to attach a tin or silver plated wire to terminals with 2.54 (0.100) or greater center spacing.  
 Wire Accommodation:  
 Jacket O.D.: 0.76 to 2.03 (0.030 to 0.080)  
 Gauge: AWG 26 to 20  
 Connector Terminal:  
 Max. Diagonal: 0.76 (0.030)  
 Height: 5.08 to 7.62 (0.200 to 0.300)
2. Sleeve will recover to 0.76 (0.030) max. I.D.
3. This drawing forms part of Raychem Specification control Drawing:  
 D-711-04, 2.54 (0.100) centers  
 D-711-07, 3.18 (0.125) centers  
 D-711-08, 3.96 (0.156) centers

<b>tyco</b> <i>Electronics</i>		<b>Raychem</b>		Tyco Electronics Corporation 300 Constitutional Drive Menlo Park, CA 94025 USA		TITLE: <b>SOLDERSLEEVE WIRE TERMINATOR</b>			
UNLESS OTHERWISE SPECIFIED DIMENSIONS ARE IN MILLIMETERS. INCHES DIMENSIONS ARE BETWEEN BRACKETS.				DOCUMENT NO.: <b>D-141-31</b>					
TOLERANCES: 0.00 N/A 0.0 N/A 0 N/A		ANGLES: N/A  ROUGHNESS IN MICRON		Tyco reserves the right to amend this drawing at any time. Users should evaluate the suitability of the product for their application.		DATE: 17-July-00		DOC ISSUE: 1	
DRAWN BY: M. FORONDA		CAGE CODE: 06090		REPLACES: N/A		DCR NUMBER: D000398		PROD. REV.: E	
						SCALE: None		SIZE: A	
								SHEET: 1 of 1	

If this document is printed it becomes uncontrolled. Check for the latest revision.